

WIDE Technical-Report in 2006

JGNII (Japan Gigabit Network II)
wide-tr-kanaumi-jgn2-00.pdf



WIDE Project : <http://www.wide.ad.jp/>

If you have any comments on this document, please contact to ad@wide.ad.jp

JGN II (Japan Gigabit Network II)

A research and development system for advanced broadband networks

Authors

- Yoshihiko Kanaumi (NEC Corporation)
- Ichiro Yamauchi (NTT Communications Corp.)
- Takashi Miyake (Kurashiki University of Science and the Arts)
- Kazumasa Kobayashi (Kurashiki University of Science and the Arts)
- Hiroshi Esaki (The University of Tokyo)

Note

About 70% of this report has been published at IPv6 Workshop in IEEE/IPSJ SAINT2006. The title of the paper is "JGN II (Japan Gigabit Network II)".

Abstract

This paper presents an overview of JGN2, Japan Gigabit Network 2, which has been established on the end of March 2004. JGN2 was built as a successor of JGN1, which has been established by Telecommunication Advancement Organization (TAO) in 1999. First, JGN2 network structure is explained. JGN2 provides gigabit level layer one, two, three functionalities to the research communities. Layer one provides optical path, layer two provides Ethernet connection, layer three provides IPv6 network respectively. JGN2 can be used not only for Japanese domestic network research but also for international network research. Network structure of North America and Asia Pacific POPs are described and it is shown how JGN2 is connected to other gigabit research network in worldwide. The demonstration experiments on JGN2 at international conferences are also described. This paper describes some demonstration experiments, High Definition(HD) TV transmission experiment at JGN2 symposium 2005, APRICOT 2005, iGrid 2005 in UCSD, Super Computing 2005 in Seattle, and Thailand - Japan Broadband Congress 2005.

1. Introduction

In Japan, we use the most inexpensive broadband Internet in the world, and amount of the high quality multimedia contents flow in the Japanese Internet grows very rapidly. As the usage of the broadband internet increases, some problems occur gradually. To use multimedia in the Internet, we need to solve many issues for VoIP, video, security, etc. The National Institute of Information and Communications Technology (NICT)[1] conducts research and development for various technologies to resolve these problems. NICT activities cover not only commercial base services but also consumer base services. NICT is also very active on the research on an international network. Japan Gigabit Network1 (JGN1) was designed for the nation-wide research and development network for high speed network infrastructure. JGN1 was used for the research on the multimedia transmission, collaboration through the network, IPv6, multicast, etc. Japan Gigabit Network 2 (JGN2) has the same objectives as JGN1, however uses different technologies. While JGN1 deployed ATM, JGN2 deployed 10Gigabit or 1Gigabit Ethernet in addition to the bandwidth increase. A nationwide IPv6 test-bed, which was the largest scale of multivendor IPv6 network was developed on the JGN1 as well. JGN2 needs to take over the JGN1 IPv6 functions. The network transition from JGN1 IPv6 to JGN2 IPv6 has been smoothly achieved last year, and JGN2 IPv6 is used continuously for various researches, for example, IPv6 multicast transmission of multiple sources at the Sapporo Snow Festival project. It is possible to send

moving image with higher quality than DV1 format, is HD2 format, and it can be IPv6 multicasted.

Furthermore JGN2 has the international POPs, Pacific Northwest GigaPoP (PNWGP), Asia Pacific POPs.

This paper describes the outline of JGN2 structure, international connection from Tokyo to PNWGP and Asia Pacific POPs, and JGN2 usage at JGN2 Symposium 2005 in Osaka are explained.

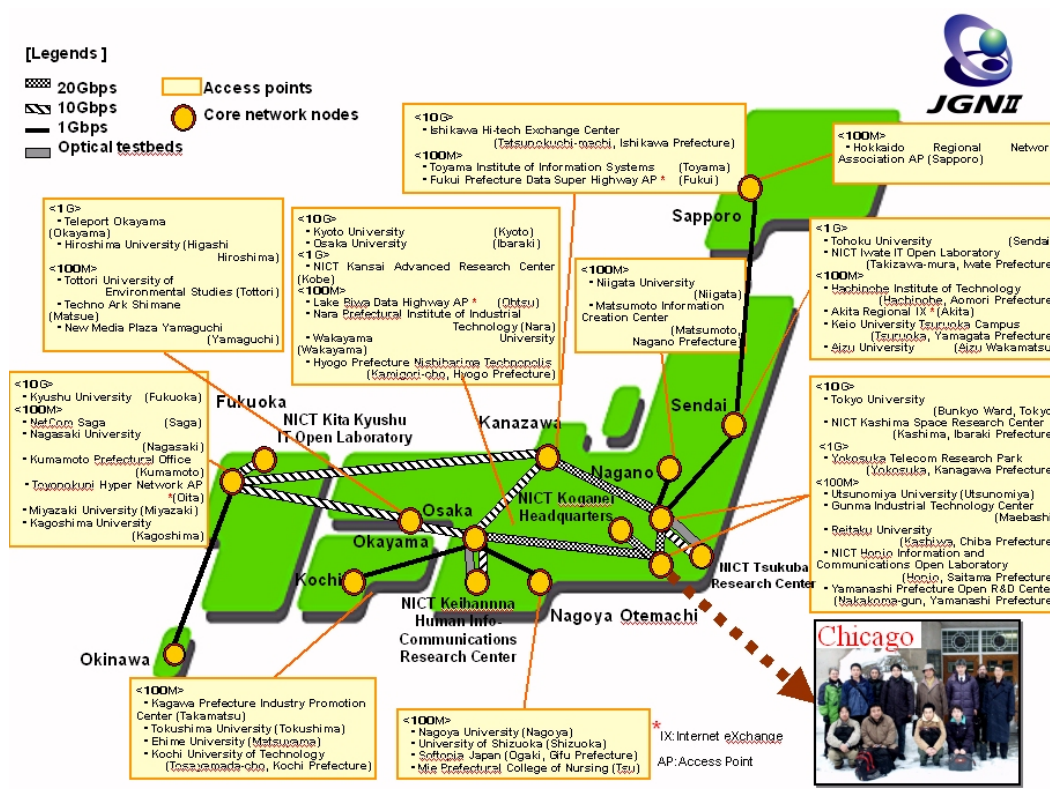

Figure 1

2. Overview of JGN2 network

JGN2 outline network is shown in Figure 1. JGN2 is composed of the following 4 functions of the network, Optical Test-bed Network, GMPLS 3 Test-bed Network, Layer 2 Ethernet Test-bed Network, and Layer 3 IPv6 Test-bed Network. Layer 3 IPv6 Test-bed Network is composed of the following 3 functions of network: IPv6 native, IPv6 multicast, and international connections. JGN2 has access points capable of providing layer 2 services not only throughout 47 prefectures and city governments (total of 63 places) in Japan, PNWGP and Asia Pacific POPs international access points. The network's entire core-nodes is connected with 10GBase-X links. At the JGN2 access points, layer 2 Ethernet and layer 3 IPv6 services are available. Additionally, the IPv6 multicast is of course available. JGN2 has access points in PNWGP and Asia Pacific POPs for international connections in addition to the Japanese locations. Details of the network such as bandwidth of every link and topology are shown in Figure 2. Figure 3 shows Layer 3 Testbed Network topology. Layer 2 and Layer 3 service provide the following:

- Layer 2 Ethernet connection/network services
 - Point-to-Point connection service. This service connects 2 points by L2 connection based on VLAN.

2. Multi-point connection service. This service connects multiple points by L2 connection based on VLAN.
- Layer 3 IPv6 connection/network services This service connects JGN2 users among each other, or to other research networks and other users, at the IP level (a service with an IPv4/IPv6 dual stack).
 - Available interfaces to JGN2 user are:
 1. 10/100/1000base-T
 2. 1000base-X
 3. 10Gbase-X, LR or ER

Layer 2 Testbed Network consists of the equipment of Layer 2 switch devices Hitachi GS4000 series and Allied Telesis CentreCOM series. Layer 3 IPv6 Testbed Network can handle BGP4+, OSPFv3, PIM-SM, MLD[3]. Layer 3 IPv6 Testbed Network consists of the router which supports those protocols with Hitachi GR4000 series, Allied Telesis SB7800R series, and NEC IP8800/R series.

JGN2 also offers the following Layer 1 services with the next generation network technologies:

- GMPLS Testbed Network
- Optical Testbed Network

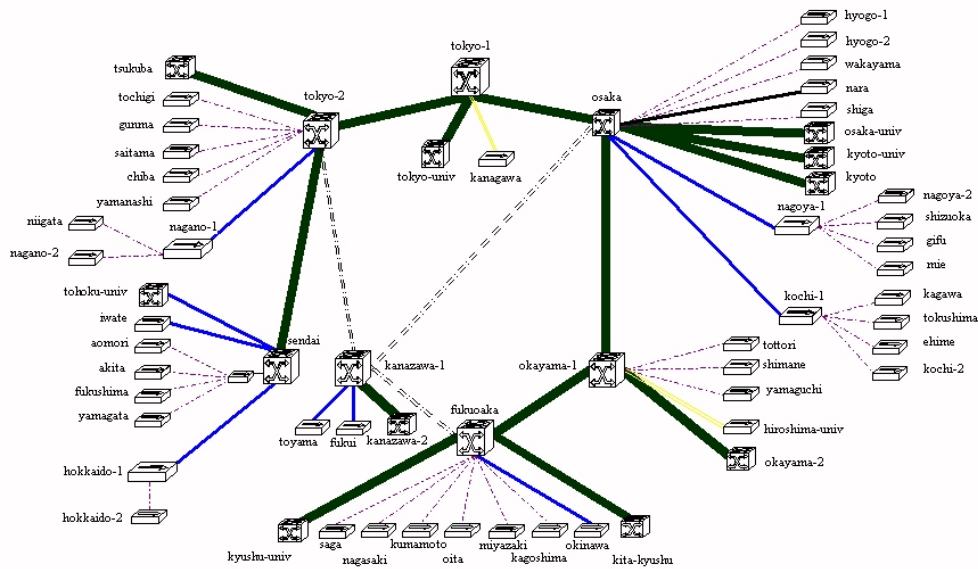

Figure 2

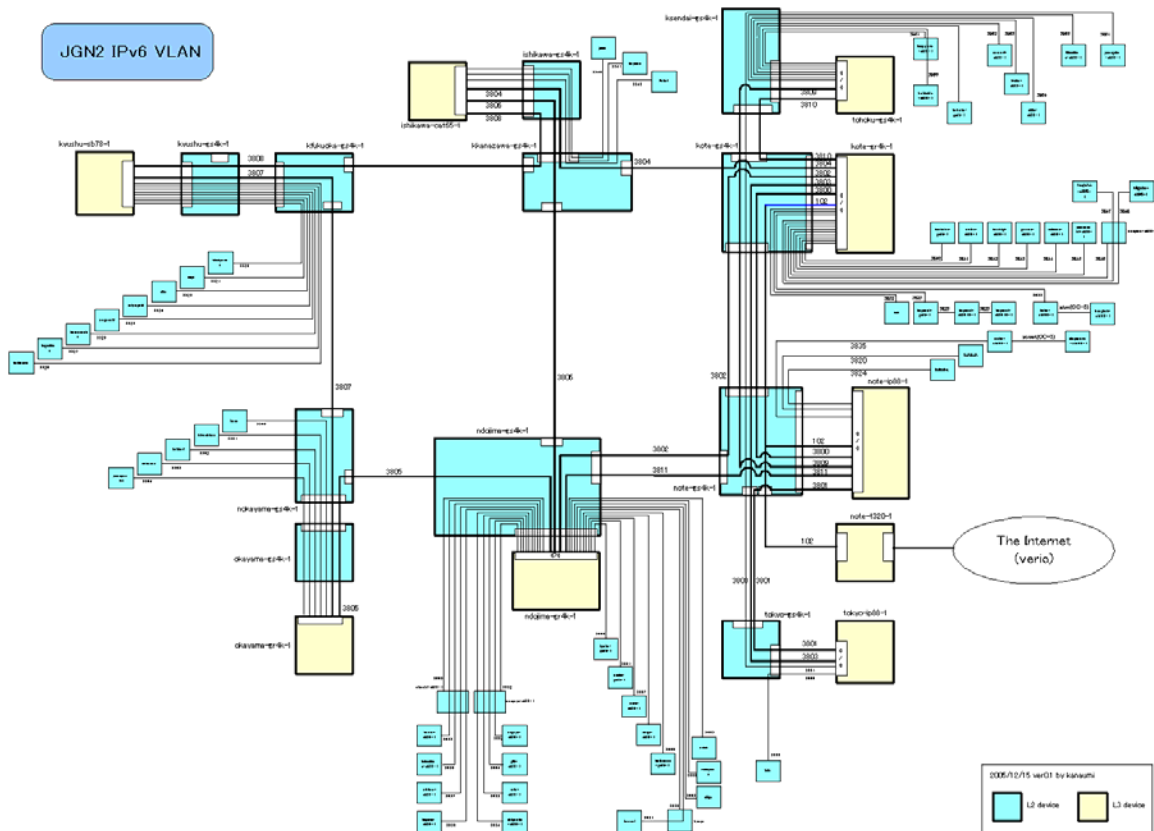

Figure 3

3. Extension to North America and Asia

JGN2 provides international Layer 2 and Layer 3 services in the same way as domestic JGN2 services. As shown in Figure 4, presently the international connection point have been constructed in the U.S.A. Configuration of JGN2 Japan-US link is as follows (in the Figure 5):

- 10Gbps (10GbE-EW) 1 line
- JAPAN (Tokyo) - USA
- To succeed TRANSPAC
- Management under (or as) JGN2 project (Link owner NICT)

JGN2 has the 10GbE-EW connection to Northwestern University, Chicago. In addition, Juniper T640 which JGN2 operates provides connection to Asia/Japan R&E networks directly, and US R&E Networks via TRANSPAC2, and Pacific WAVE. Procket 8812 is directly connected to Asia/Japan R&E networks as well.



Figure 4

3.1. Tokyo POP

Tokyo POP has JGN2 Network Operation Center which controls and manages whole JGN2 network. As shown in Figure 5, the domestic NOC is located in NTT Otemachi, and the international NOC in KDDI Otemachi.

3.2. North America POP

North America POP is located on Northwestern University, Chicago. As shown in Figure 5, we installed Hitachi GS4000/80E, Super-micro SC822R-400RC, Cisco 7960, Allied Telesis Centre-COM 9812T. Configurations of these devices are as follows:

- Hitachi GS4000/80E:
 - 3ports 10Gigabit Ether (EW, LW, LR)
 - 10GbE-EW is for Tokyo POP.
 - 10GbE-LR is for Force10, StarLIGHT.
 - 10GbE-LW is for reserve.
 - 12ports 1Gigabit Ethernet (SX)
- Supermicro SC822R-400RC:
 - Pentium4 3GHz, Mem 512MB*2, HDD SEAGATE 250GB*2(RAID-1), 100Base-TX*2, 1000Base-SX*1

- Allied Telesis CentreCOM 9812T:
12ports 10/100/1000Base-TX, 4ports 1Gigabit Ethernet (SX)
- Cisco 7920:
usage as the communication tool for the operators, and installation of Call Manager in
NTT Otemachi, Tokyo

In order to login to these devices except Cisco 7920, operators must login to Supermicro SC822R-400RC server. Therefore Supermicro SC822R-400RC server is set ACLs to limit the network login. Furthermore, we'll only use SSH for remote login.

And North America POP has the interconnection to StarLight, Abilene, CA*net4, TransLight, NLR, CAVEwave and SURFnet.

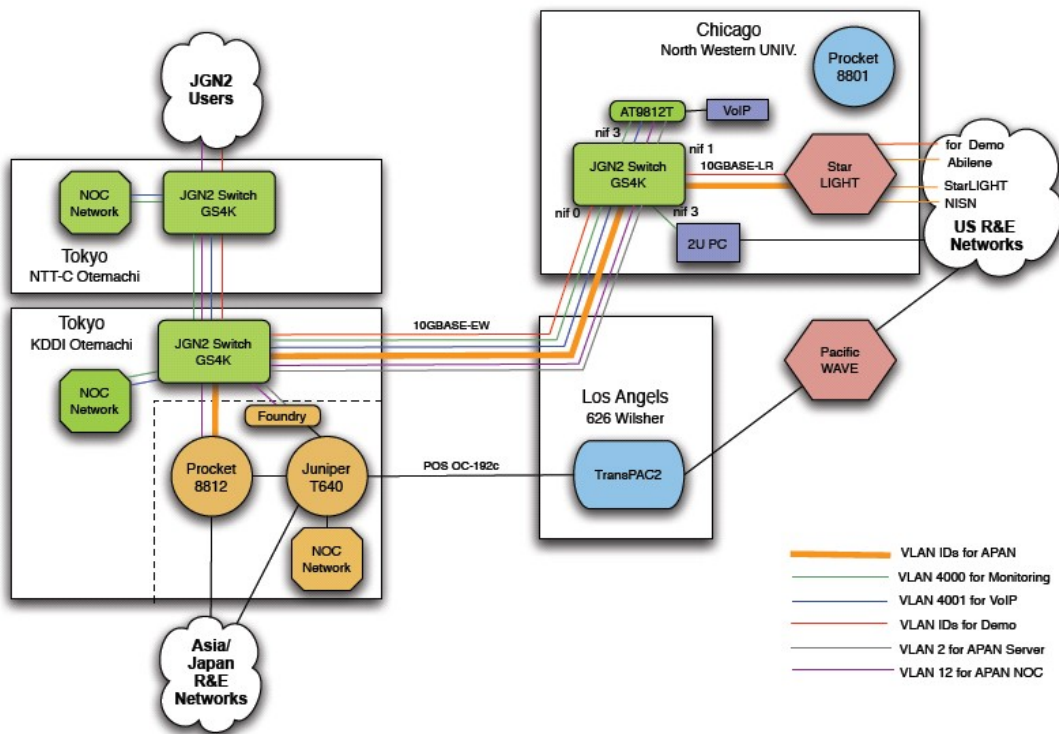

Figure 5

3.3. Asia POP

JGN2 Asia Pacific POP opens in November 2005. Configurations of Asia Pacific POP are similar to North America POP and provide Layer 2 and Layer 3 connections to the APAN group Asian countries shown in Figure 6.

3.3.1. Bangkok POP

Bangkok POP is located on Bangkok ThaiTower, ThaiSarn[4] NOC. We installed Foundry NetIron400, L2-SW and Alternate Access PC. Details are as follows;

- Foundry NetIron400
2port ATM OC-3
Connection between Bangkok and KDDI Otemachi with ATM 70Mbps (OC-3)
8port 100Base-X (SFP): 2port 1000Base-LX, 4port 1000Base-SX, 2port 1000Base-T
- L2-SW and Alternate Access PC

And Bangkok POP has the interconnection to ThaiSarn/ThaiREN/TEIN2.

3.3.2. Singapore POP

Singapore POP is located on Global Switch Data Center, SingAREN[5]. We installed Foundry NetIron400, L2-SW and Alternate Access PC. Details are as follows;

- Foundry NetIron400
2port SONET/SDH OC-3
Connection between Bangkok and NTT Otemachi with SONET/SDH (STS-3)
8port 100Base-X (SFP): 2port 1000Base-LX, 3port 1000Base-SX, 3port 1000Base-T
- L2-SW and Alternate Access PC

And Singapore POP has the interconnection to SingAREN GIX/TEIN2.

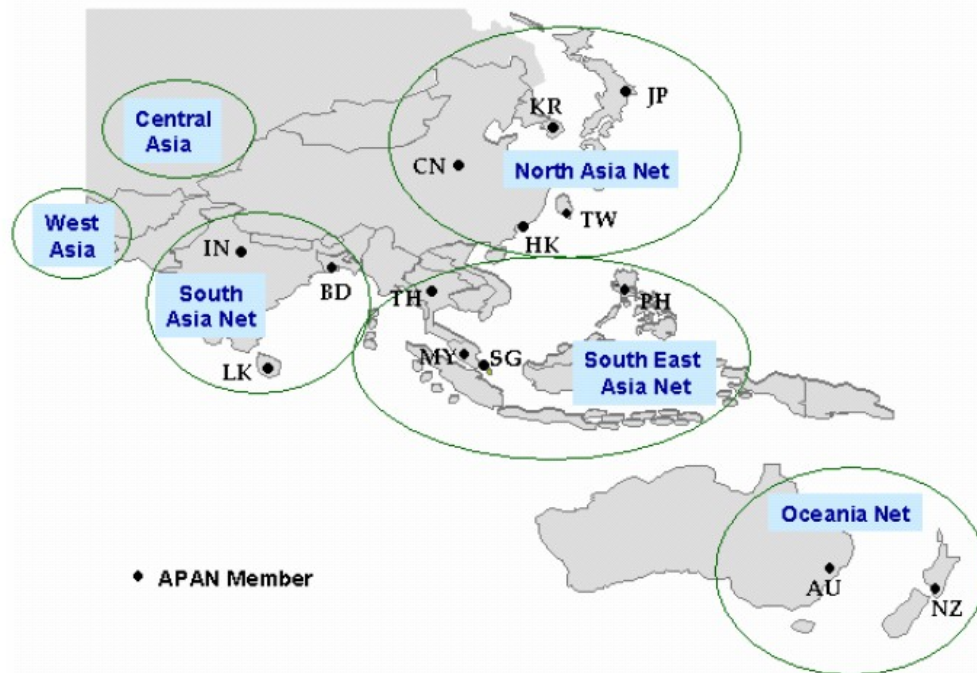

Figure 6

4. The international conferences and Demonstrations

In this section, two events which use JGN2 are described to show how effective the network is for international events.

4.1. JGN2 Symposium 2005 in Osaka

January 20, 2005 – Dignitaries and researchers were attending the JGN2 Symposium 2005 in Osaka, Japan. This week listened and watched as Internet visionary Larry Smarr gave the keynote presentation on a large high-definition television (HDTV) screen above the podium. Unlike traditional keynote speakers, Smarr was 5,000 miles away in Seattle, Washington, but the picture was so clear that Osaka attendees could even distinguish a hair on the speaker's head. Advances in transmitting live, uncompressed HDTV signals over optical networks are enabling true tele-presence, in which participants feel they were together in the same room. The Internet HDTV broadcast system used for this event was developed by the University of Washington for the ResearchChannel. A server in Seattle transmitted uncompressed, real-time, high-definition digital video and digital audio at very high quality and in low latency to a client system in Osaka. Professor Smarr's presentation originated on the University of Washington campus in Seattle and was transmitted without any compression at 1.5 Gbps to the Pacific Northwest GigaPoP (PNWGP)[6], then across a 10Gbps transpacific link from Seattle to Tokyo, and then via the JGN2 to Osaka. The transpacific link was provided by the Internet Educational Equal Access Foundation (IEEAF)[7], and is managed by the PNGWG in Seattle and the WIDE project[8] in Japan. The network of JGN2 symposium is shown in Figure 7

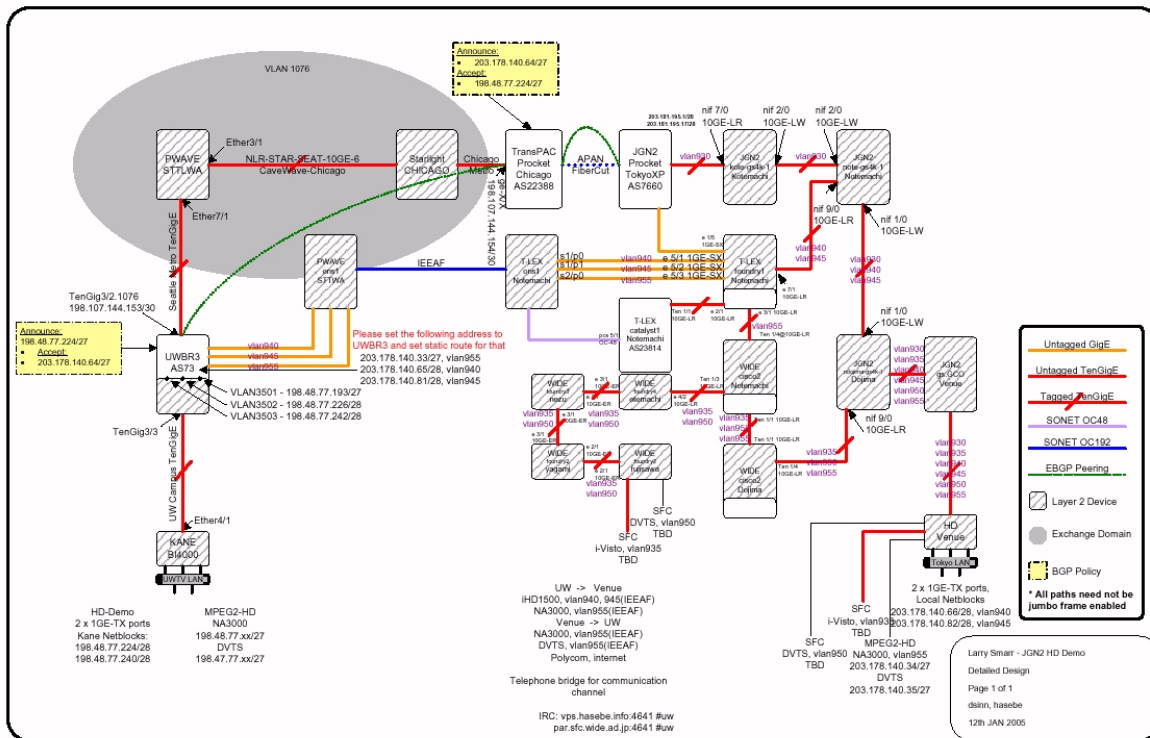

Figure 7

4.2. APRICOT 2005 in Kyoto

The APRICOT 2005 Kyoto from February 18th to 25 day was held in Kyoto International Conference Hall (KICH). Inside the conference place wireless LAN service and wired service in the exhibition space was offered. It was possible to use the service of the wireless LAN telephone. JGN2 Symposium Network T-LEX, WIDE project network, and JGN2 are utilized to connect the Internet.

4.3. Thailand - Japan Broadband Congress 2005

In commemoration the links of Thailand and Singapore have opened, Thailand - Japan Broadband Congress was held on November 22, 2005. In one program of opening ceremony, three places, Thailand, Osaka University, and Hyogo University, were connected with using Digital Video Format streaming over IPv6. Network topology is shown as Figure8.

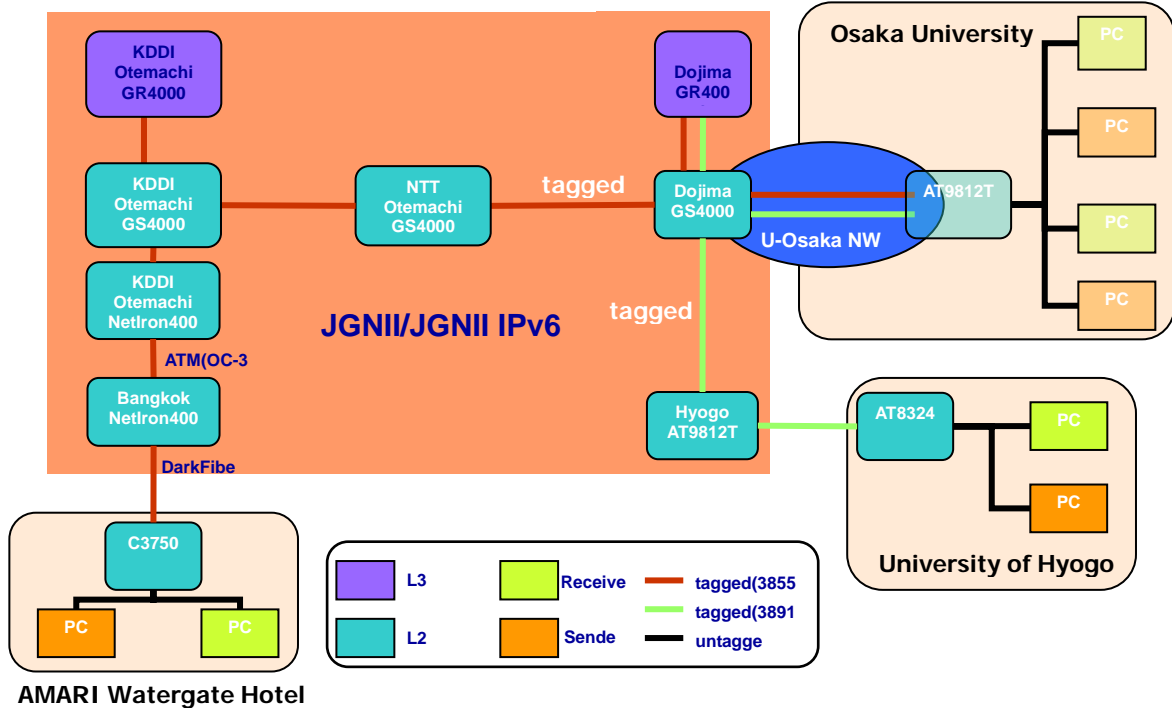

Figure 8



AMARI hotel, Thailand



Osaka University



Hyogo University



Panel discussion in AMARI

Figure 9

4.4. iGrid 2005 in the University of California, San Diego (UCSD), USA

NICT joined to iGrid 2005 in the University of California, San Diego (UCSD), and performed experiments on IP transmission of long distance and broadband. JGN2 constructed experimental environment of parts of Japan and Pacific for the success in the experiments, and supported demonstration experiments of the network operation technology adapted the various applications. This experiments prove that JGN2 operated and managed by NICT cooperates the overseas research network (StarLIGHT, Abilene and so on) each other and constructs a long distance and broadband global network of about 15,000km.

iGrid 2005 network is shown as Figure 10.

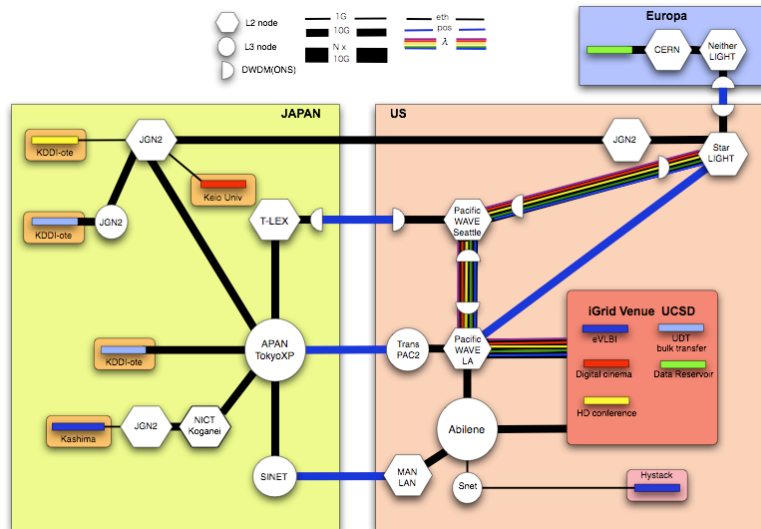

Figure 10

Project Name	Bandwidth of International Link	Bandwidth of Domestic Link	Protocol	MTU	Routing
Data Reservoir	JGN2 10 Gbps (Tokyo->Chicago) IEEEAF 10Gbps (Seattle->Tokyo)	T-LEX 10 Gbps (TokyoXP->T-LEX)	IPv6 TCP	8K	Static
AIST, GTRC Grid	Only little traffic	-	-	-	-
UIC & Kitakyushu JGNII RC	JGN2 10 Gbps	JGN2 Domestic 10 Gbps	UDT	1.5K and 9K	Layer3 (Static and BGP)
Digital cinema	JGN2 1 Gbps	JGN2 Domestic 1 Gbps	UDP	1.5K	Layer 2 (VLAN path) and Layer 3 (Static and BGP)
eVLBI	JGN2 1 Gbps (JP<->US)	Domestic 1 Gbps (Kashima<->Tokyo)	-	1.5K	Layer 2 (VLAN path)
Osaka-U	TransPAC2 or JGN2 150/1 Mbps (JP->US/US->JP)	JGN2 Domestic 150/1 Mbps (Osaka->TokyoXP/TokyoXP->Osaka)	IPv4 UDP, TCP	1.5K	Layer 3 (BGP routing)

Table 1

4.5. Super Computing 2005 in Seattle, USA

In the same way as iGrid 2005, the link of Japan and North America in JGN2 was used for demonstration experiments for a long distance and broadband transmission. Specifically, a long distance and broadband network backbone was installed for the cooperation of JGN2 and the overseas research networks (StarLIGHT, Abilene, and so on), and JGN2 was used for various demonstration experiments (as the target of most long-distance and highest speed data transmission using UDT protocol, network QoS technology for effective utilization, information technologies of grid architecture and access control technology for next generation, e-VLBI, and three dimensions simulation of universe weather).

Super Computing 2005 network is shown as Figure 10.

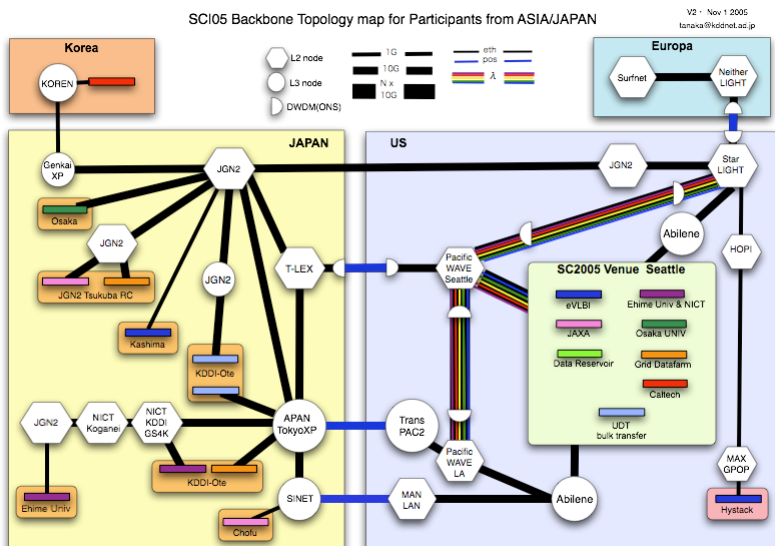

Figure 11

Project Name	Bandwidth of International Link	Bandwidth of Domestic Link	Protocol	MTU	Routing
Data Reservoir (Entry for the Bandwidth Challenge)	JGN2 10 Gbps (Tokyo->Chicago) IEEAF 10Gbps (Seattle->Tokyo)	T-LEX 10 Gbps (TokyoXP->T-LEX)	IPv6 TCP	8K	Static
AIST, GTRC	TransPAC2 10Gbps (JP<->US)	JGN2 Domestic 10Gbps (Tsukuba<->TokyoXP)	-	1.5k	BGP via TransPAC2
JAXA (Entry for the Bandwidth Challenge)	JGN2 10Gbps	JGN2 Domestic 10Gbps - Local 10Gbps	IPv6, TCP	1.5K and 9K	Static
UIC & Kitakyushu JGNII RC (Entry for the Bandwidth Challenge)	JGN2 10 Gbps TransPAC2 10Gbps	JGN2 Domestic 10Gbps Local 10Gbps	UDT	1.5K and 9K	Static and BGP(A) for TransPAC2(B) for JGN2
Osaka Univ.	-	-	-	-	BGP via TransPAC2
eVLBI	JGN2 1 Gbps (JP<->US)	JGN2 Domestic 1 Gbps (Kashima<->Tokyo)	-	1.5K	-
Caltech (Entry for the Bandwidth Challenge)	TransPAC2 1 Gbps	JGN2 Domestic 1 G	-	1.5K	BGP via TransPAC2
Real-Time Visualization over High-Performance Network (Entry for the Bandwidth Challenge)	TransPAC2 less than 3 Gbps	NICT GS4K	UDT	9k	BGP via TransPAC2

Table 2

5. JGN2 IPv6

JGN2 IPv6 network has two objectives;

1. The promotion to the usage of IPv6
 - Snow festival 2004/2005/2006(planning now) in Sapporo, Japan
 - Okayama Kokutai 2005 in Okayama, Japan
 - LIVE! ECLIPSE 2005 Annular
 - <http://www.live-universe.org/index.html>
 - Ceremony of release artificially raised five white storks into the wild, Hyogo Prefecture
Homeland for the Oriental white Stork, Japan
 - IPv6 summit in HIROSHIMA2005
2. The conductions of the demonstration experiments of IPv6 and the developments on various technologies for IPv6

Network summary;

1. Construction on JGNII
 - Connection with 10Gigabit Ethernet (LAN-PHY/WAN-PHY), Gigabit Ethernet and Fast

- Ethernet
2. 64 access points (include 8 hubs and 56 leaf points)
 - In charge of IPv6 Unicast(OSPFv3) and Multicast(PIM6-SM:RP) routing for the eight hubs
 3. Global IPv6 connectivity by 2001:e38::/32
 4. IPv6 Multicast ready
 - PIM6-SM and MLD snooping at all of L3/L2 devices
 - Three Rendezvous Points for CPU load balancing

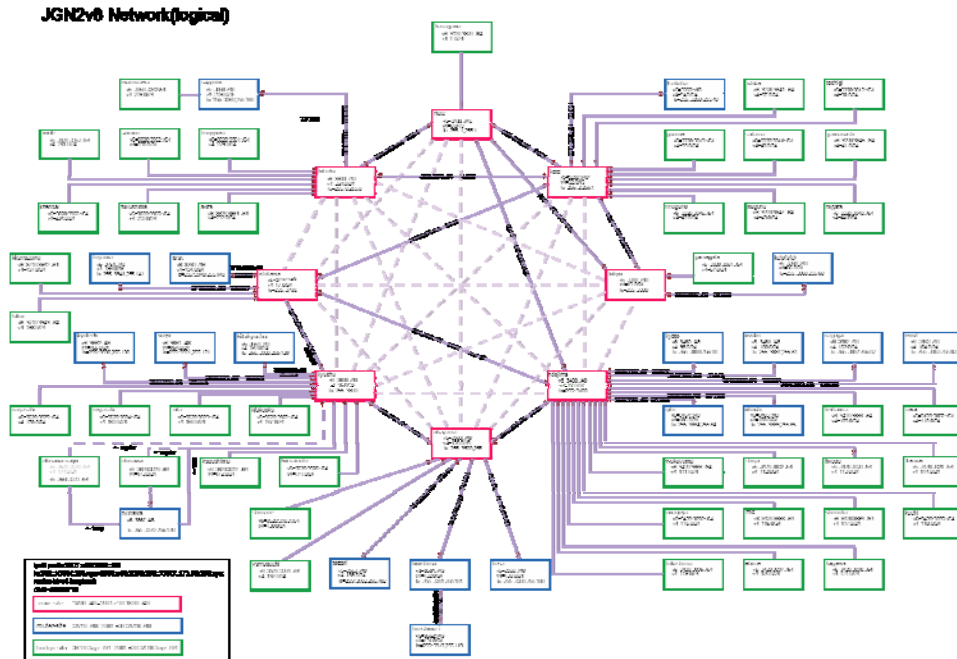

Figure 12

5.1. Multi-source Multicast Transfer Trial

In 2004 and 2005 snow festival, the live broadcast is transmitted with Digital Video Format streaming over IPv6 of single source multicast. On the contrary, in Okayama Kokutai, the transmissions and receptions of Digital Video/Compressed HDTV over IPv6 multicast are used at the simultaneous multipoint. This multicast streaming consume about 2.1Gbps (max) on aggregate. The senders are installed the software of DV sender to more than 47 PCs and Robst to 2-3 PCs. The receivers are installed the software of the DV client to more than 340 PCs and the Robst/Video LAN to 2-3 PCs. IPv6 Multicast group address sets about 50 group addresses, in brief about 50 channels. And the rendezvous points are configured to GS4000 series in Dojima, Okayama and Kyushu. In Figure 13, it is shown that this event network is applied to Okayama information highway network.

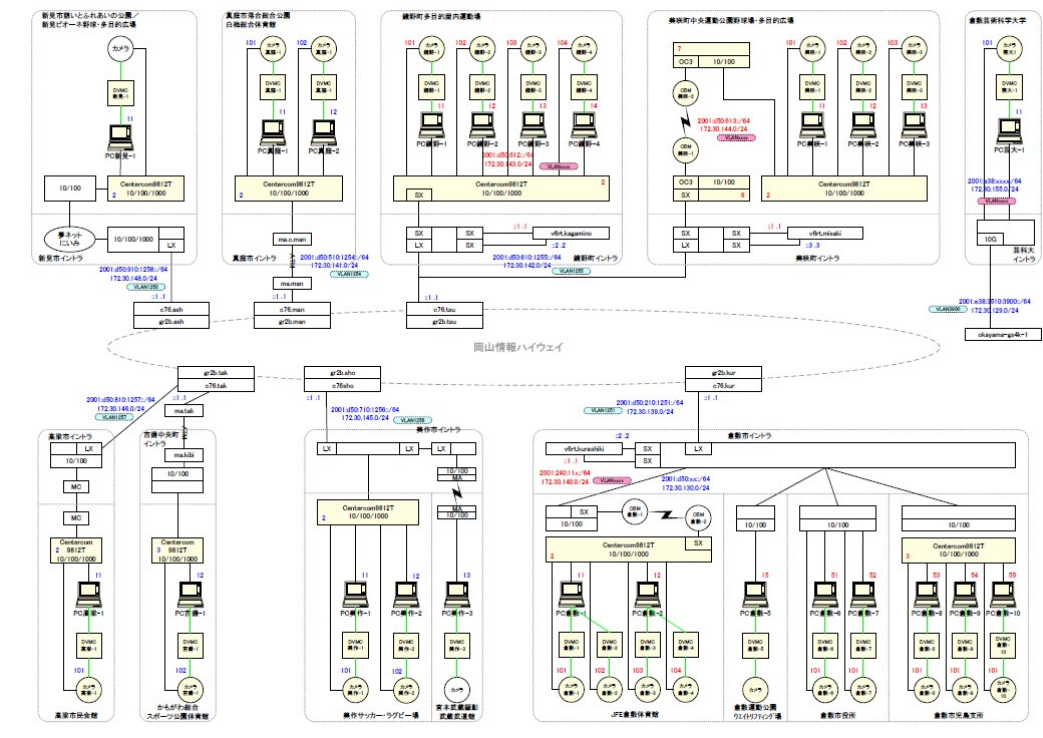

Figure 13

6. Conclusions

- 10Gigabit Ethernet based nation wide R&D network JGN2 is explained.
- JGN2 provides Layer2 connections as well as Layer3(IPv4/IPv6) connections
- JGN2 is use not only for R&D but also for international research conference.

7. Acknowledgements

We appreciate all the people contribution to JGN2 world wide. Specially, when JGN2 and JGN2 IPv6 are constructed, many people relate, appreciate in those people. In the future, in order to be able to use in for many researchers, you watch the state of network, keep trying to release the data widely.

References

[1] N. I. of Information and C. Technology. NICT – National Institute of Information and Communications Technology. <http://www.nict.go.jp>, 2004.

[2] JGN2

JGN2 is a new Japanese ultra-high-speed open testbed network for R&D collaboration between industry, academia, and government, operated by the National Institute of Information and Communications Technology (NiCT) of Japan. JGN2 was established in April 2004 with the aim of promoting a broad spectrum of research and development projects, ranging from fundamental core

research and development to advanced experimental testing, in areas including the advancement of next generation technologies for networking and diverse network-based applications. JGN2 provides nationwide Japanese IP networks, optical wavelength networks, and R&D environments for optical testbeds. JGN2 was extended internationally in August 2004 with the addition of a 10 Gbps transpacific link between Japan (Tokyo) and the USA (Chicago). <http://www.jgn.nict.go.jp/e/>

[3] B. Haberman. Source Address Selection for the Multicast Listener Discovery (MLD) Protocol. RFC 3590, 2003.

[4] ThaiSarn

The National Electronics and Computer Technology Center (NECTEC) setup a national-wide network called Thai Social/Scientific Academic and Research Network (ThaiSarn) in 1992 in order to promote the use of the Internet in Thailand. ThaiSarn is currently in its third generation, denoted as ThaiSarn3, where the main mission is to promote research in networking technologies and applications. At present, ThaiSarn3 is currently connected to 3 major international research networks; <http://thaisarn.nectec.or.th/>

[5] SingAREN

Singapore Advanced Research and Education Network (SingAREN) started as a national project funded by the government in 1997 to take on the challenge of ensuring that Singapore research and education (R&E) community is connected to the international R&E community. Being the national research and education network (REN), it has maintained network connectivity to the global Next Generation Internet (NGI) community such as Internet2 and APAN (Asia Pacific Advanced Network). <http://www.singaren.net.sg/>

[6] Pacific Northwest Gigapop

The Pacific Northwest Gigapop (PNWGP) is a not-for-profit corporation serving leading edge organizations and Research and Education networks throughout the Pacific Rim. PNWGP provides robust, highest-speed access to current state of the art Internet; Next Generation Internet services and technology; and the exclusive R&D testbeds where tomorrow's Internet technologies are being developed. PNWGP is built to be the highest caliber Research and Education networking services hub in the world and is the operator of the Pacific Wave distributed west coast international peering and exchange point with integrated pop's in Seattle and Los Angeles. The Pacific NorthWest Gigapop is also the steward for Seattle end of the IEEAF Pacific links. <http://www.pnw-gigapop.net>

[7] IEEAF

The Internet Educational Equal Access Foundation (IEEAF) is a non-profit organization whose mission is to obtain donations of telecommunications capacity and equipment and make them available for use by the global research and education community. The IEEAF TransPacific Link is the second 10 Gbps transoceanic link provided by IEEAF through a five-year IRU donated by Tyco Telecom; the first, the IEEAF TransAtlantic Link, connects New York and Groningen, The Netherlands, and has been operational since 2002. IEEAF donations currently span 17 time zones. <http://www.ieeaf.org/>

[8] WIDE project

WIDE, a research consortium working on practical research and development of Internet-related technologies, was launched in 1988. The project has made a significant contribution to development of the Internet by collaborating with many other bodies -- including 133 companies and 11 universities to carry out research in a wide range of fields, and by operating M.ROOT-SERVERS.NET, one of the DNS root servers, since 1997. WIDE Project also operates T-LEX (www.t-lex.net/) as an effort of stewardship for the IEEAF TransPacific Link in Tokyo. <http://www.wide.ad.jp/>

プレスリリース

「日本の研究チームがインターネット速度記録全種目を獲得」
－従来の IPv6 速度記録を大幅に更新－

東京大学大学院情報理工学系研究科
平木 敬

2005 年 11 月 17 日

要旨

東京大学、WIDE プロジェクト、(株) 富士通コンピュータテクノロジーズ、チェルシオ・コミュニケーションズ (米国)、JGN2(日本)、パシフィック・ノースウェストギガポップ (米国)、NTT コミュニケーションズ(株)が 10 月 28 日、29 日に共同で実施した実験の結果が米国 Internet2 の Internet2 Land Speed Record (インターネット速度記録) に IPv6 における 2 種目で認定されました。これは、カリフォルニア工科大学が持っていた IPv6 におけるインターネット速度記録の 2.3 倍の記録です。この結果、IPv4 および IPv6 の合計 4 種目全てのインターネット速度記録において日本を中心とした研究チームが保持しています。

記録に用いたインターネットは、東京 → シカゴ → 東京 → シアトル → 東京 であり、東京に設置した東京大学の 2 台の PC 間でデータ転送を行いました。データ転送速度は 1 秒間に 5.58 ギガビット (約 56 億ビット) 毎秒です。将来のインターネット標準規格として、日本を中心に推進している IPv6 インターネット規格を用いて、従来から用いられてきた IPv4 インターネットとほぼ同等の性能が達成できることを実証しました。

実験の詳細は <http://data-reservoir.adm.s.u-tokyo.ac.jp/lsr-20051029/sub.html> を参照して下さい。

Internet2 からのプレス発表は

<https://mail.internet2.edu/wws/arc/i2-news/2005-11/msg00004.html>

Internet2 Land Speed Record (インターネット 2 ランドスピードレコード) は

<http://lsr.internet2.edu/> に過去の記録を見ることができます。

この結果は、日本の高速インターネット技術が世界の最高レベルであることを具体的な形として示しています。

<http://data-reservoir.adm.s.u-tokyo.ac.jp/press/lsr-20051115-j> に本発表文書があります。

1. 詳細

東京大学、WIDE プロジェクト、(株) 富士通コンピュータテクノロジーズ、チェルシオ・コミュニケーションズ (米国)、JGN2(日本)、パシフィック・ノースウェストギガポップ (米国)、NTT コミュニケーションズ(株)が 10 月 28 日、29 日に共同で実施した実験の結果が米国 Internet2 の Internet2 Land Speed Record (インターネット速度記録) に IPv6 における 2 種目で認定されました。これは、カリフォルニア工科大学が持っていた IPv6 におけるインターネット速度記録の 2.3 倍です。

今回の記録は、米国カリフォルニア工科大学が平成 17 年 1 月 19 日に達成した記録の 2.3 倍の記録を達成し、IPv6 を用いた単一ストリーム TCP クラスと複数ストリーム TCP クラスの双方での記録となったものです (表 1)。この結果、12 月 24 日に東京大学、WIDE プロジェクト他の国際共同チームが達成した IPv4 を用いた単一ストリーム TCP クラス、複数ストリーム TCP クラスと併せ、インターネット速度記録の全種目において日本を中心とした研究チームが保持しました。

この記録は、今後、インターネットの普及に伴う IP アドレスの不足を解消し、また将来開発されるであろう様々な技術の基盤として位置づけられている IPv6 においても、10 ギガビットネットワークの高効率利用が特殊な方式なしで実現することを示しました。現在、多くの PC やサーバが扱っている大多数のアプリケーション、例えばウェブページのアクセス、メール通信、ファイル転送などが直接的に利用できることを意味し、今後数年間のネットワーク利用の高速化が、標準のイーサネット、標準の TCP 通信方式で実現することが可能であることを示しました。

具体的には、CD 一枚のデータを 0.7 秒、DVD 一枚を 5 秒、100 ギガバイトのディスク一個分のデータを約 110 秒で地球の反対側に送ることに相当するものです。

インターネット速度記録を実現したネットワークは、東京に設置された 2 台の東京大学のサーバ間を、下記ネットワークで結合しました。

東京ネットワーク接続	T-LEX(WIDE プロジェクトが運営)
東京 ⇒ シカゴ	JGN2
シカゴ ⇒ 東京	JGN2
東京 ⇒ 東京大学	WIDE
東京大学 ⇒ 東京	JGN2
東京 ⇒ シアトル	IEEAF
シアトル・ネットワーク接続	Pacific Northwest Gigapop
シアトル ⇒ 東京	IEEAF

2 台のサーバ間の距離は、中間にある機器間の最短距離の和で測ると 35,755 km となりますが、Internet2 のランドスピードレコードのルールにより、30,000 km として記録は計算されました。このネットワーク上のデータ転送速度が 5.58Gbps であったことから、今回認定された記録は 167,400 テラビット・メートル/秒となりました。

この記録は単一 TCP ストリームを用いたもので、IPv6 通信での従来の記録の 2.3 倍であるため、LSR に認定されました。また、従来の複数ストリーム TCP クラスの記録の 2.3 倍であることから、複数ストリーム TCP クラスの記録としても認定された次第です。なお、ネットワークの往復遅延時間 (RTT) は約 500 ミリ秒です。

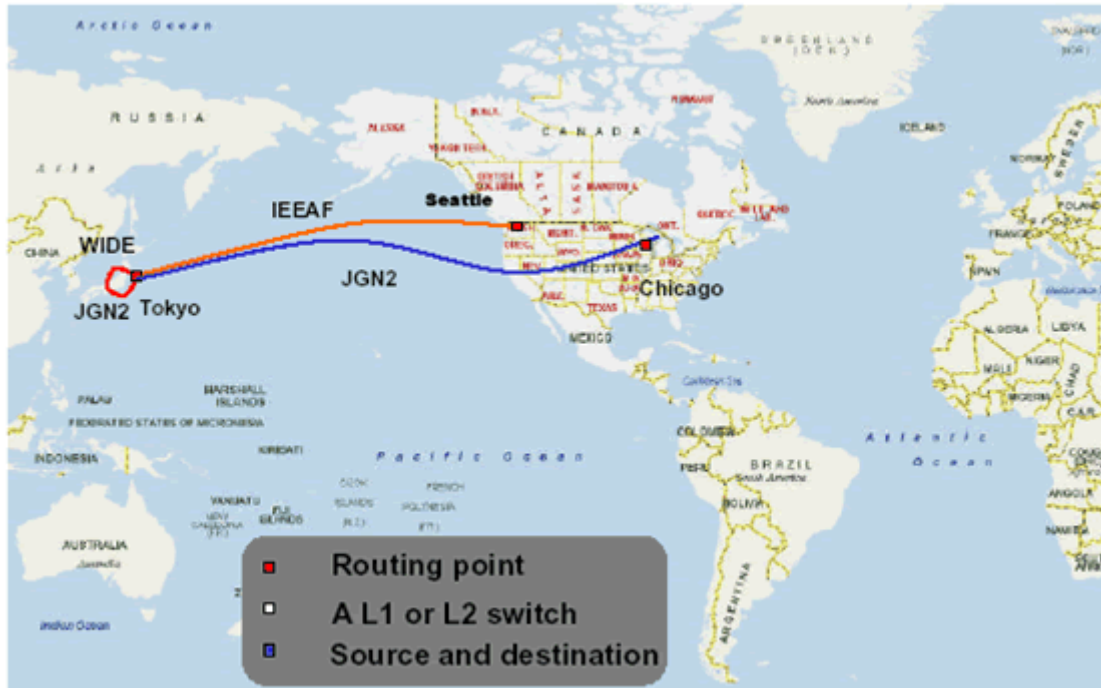

この記録に関して特筆すべきことは、以下の通りです：

1. データ通信が、インターネット規格として重要である IPv6 で実現したことは、この技術が将来、携帯通信、ユビキタス情報技術を含む広い分野へ適用可能であることを意味していること。Web アクセス、ファイル転送、メールシステム、GRID などは想定される応用分野です。

2. 両端に設置したサーバは、特殊なものではなく一般的に入手可能な標準的部品を組み合わせた PC であること (約 30 万円の PC および普通に入手可能な 10 ギガビットのネットワークアダプタ)。

3. 5.58Gbps のデータ転送速度は、TCP を実現するソフトウェアとネットワークの安定性で決まりました。東京大学が研究開発した「レイヤ間協調による最適化」技術が遠距離・高バンド幅 TCP 通信の持つ問題点をここでも解決したことを意味していること。

4. 日本のネットワーク技術が世界最高レベルに達していること、日本と世界の学術ネットワーク間の密な結合を、具体的な形で示したこと。

なお、本成果は、科学技術振興調整費「重要課題解決型研究等の推進」プログラムの実施課題「分散共有型研究データ利用基盤の整備」によるものです。

この実験は、次の企業による機材の提供やサポートを得て実現されました：Cisco Systems、東陽テクニカ、Foundry Networks、物産ネットワークス、およびネットワンシステムズ。

連絡先：

東京大学大学院情報理工学研究所コンピュータ科学専攻 教授

平木 敬 e-mail: hiraki@is.s.u-tokyo.ac.jp

電話：090-6482-9169

(現在、米国シアトルに出張中ですが、上記電話番号、または e-mail で連絡可能です)

実験参加者：

東京大学

平木 敬、稲葉真理、玉造潤史、菅原 豊、稲上克史、青嶋奈緒、中村 誠
(株)富士通コンピュータテクノロジーズ

来栖竜太郎、坂元眞和、古川裕希、生田祐吉

WIDE プロジェクト

加藤 朗、山本成一、関谷勇司

NTT コミュニケーションズ

長谷部克幸、村上満雄、根尾美由紀、稲田 友

チェルシオ・コミュニケーションズ (米国)

Felix Marti、Wael Noureddine

JGN2

中村一彦、豊田麻子、小林克志、月岡陽一、田中 仁、服部佳隆

Pacific Northwest Gigapop

Jan Eveleth、Bill Mar、Beth Garrison

ネットワーク担当機関 (西から東)：

WIDE

JGN2

IEEAF(Internet Educational Equal Access Foundation)

ネットワーク接続ポイント機関：

T-LEX, Pacific Northwest Gigapop

Full Copyright Statement

Copyright (C) IEEE-CS and IPSJ (2005-2006). All Rights Reserved.

Copyright (C) WIDE project (2005-2006). All Rights Reserved.